

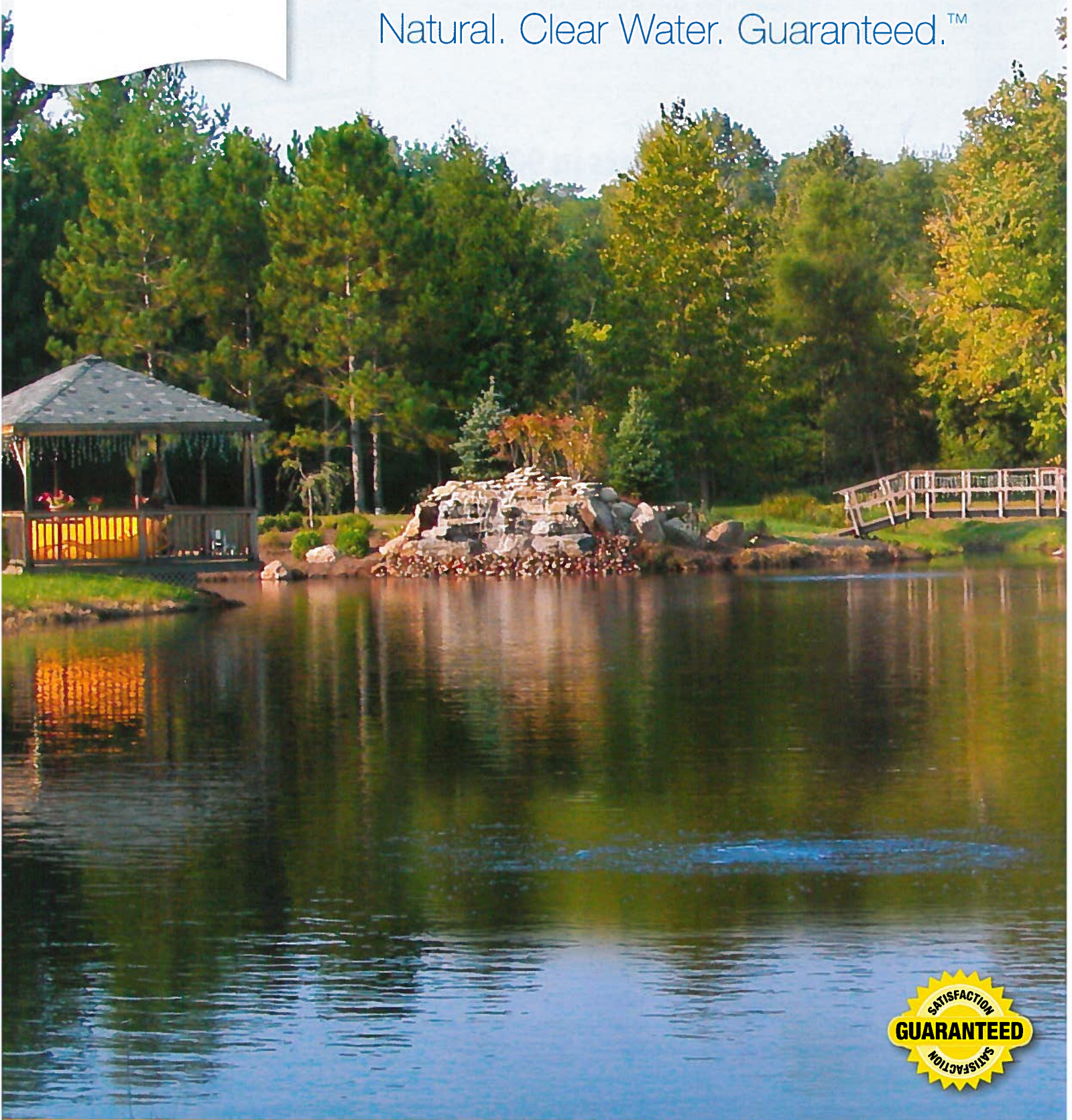

# 2011-2012 Professional Product Guide

*Featuring Pond Logic® products for Pond & Lake Management*

Natural. Clear Water. Guaranteed.™



**866-4-AIRMAX**  
866.424.7629

[www.airmaxeco.com](http://www.airmaxeco.com)



# A Case for Airmax® Aeration

Building a Case for Airmax®

## Airmax® Aeration: An Easy Choice



- Quietest aeration system on the market.
- High-performance, self-weighted, virtually maintenance-free diffuser.
- Backed by a complete SATISFACTION GUARANTEE.
- Lowest cost of operation.
- Easy to install with virtually no assembly!
- 2-year compressor and electrical components warranty.
- 5-year diffuser warranty.
- Lifetime cabinet warranty
- Made in USA.

## 90% Reduction in Nutrients in 90 Days

A commercial pay-to-fish lake had heavy algae blooms and high levels of nutrients. The lake is 8 acres and 10 feet in depth. The lake is stocked with over 25,000 lbs of carp and 10,000 lbs of catfish. Fish are fed daily with a high protein fish food. We tested the water for phosphorus and nitrogen and discovered the nutrients levels were high. We also tested dissolved oxygen (DO) to get a feel of oxygen levels at the bottom of the lake, biochemical oxygen demand (BOD) to see how much oxygen was needed to create an environment for aerobic bacteria and oxidation reduction potential (ORP) and found that there was limited oxygen supply towards the bottom of the lake and a very high BOD resulting in almost zero aerobic bacteria activity.

**PRESCRIPTION:** – We need to increase oxygen levels to promote healthy fish and aerobic bacterial activity as well as bring down nutrient levels. Based on the depth and size of the lake, we recommended TWO AM100, 6 plate, deep water aeration systems.

**RESULTS:** We tested DO, BOD, ORP, Nitrogen & Phosphorus initially and once a month after for 3 months. DO increased and became saturated throughout the water column. BOD dropped near zero. BOD, nitrogen and phosphorus dropped dramatically to almost zero in the first 90 days.



### Improved Water Clarity through Nutrient Reduction

Nitrogen Levels in the Water

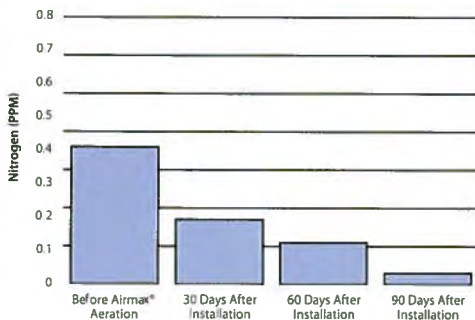

Phosphorus Levels in the Water

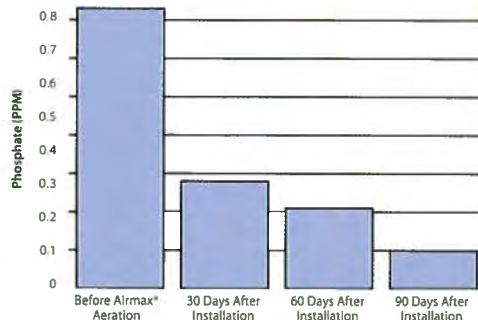

### Improved Aerobic Bacterial Activity and Healthier Fish through Oxygen Saturation

Dissolved Oxygen at 10' of Depth

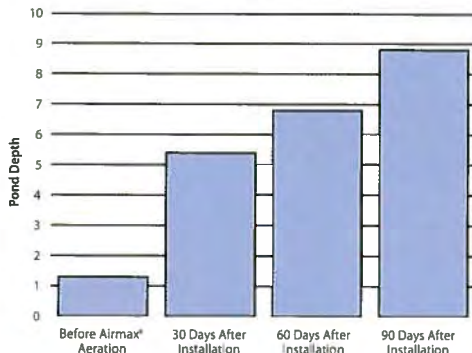

Biochemical Oxygen Demand (BOD)

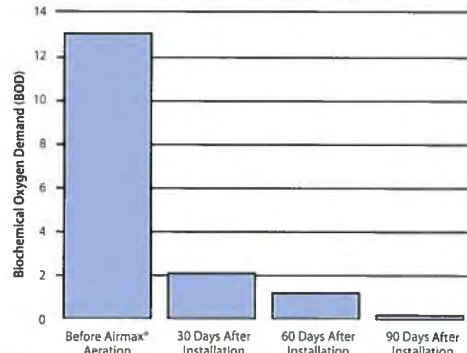

Oxidation Reduction Potential (ORP)

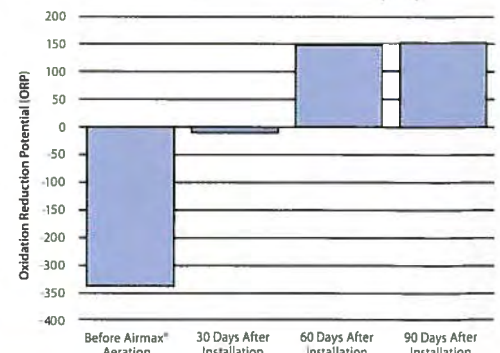



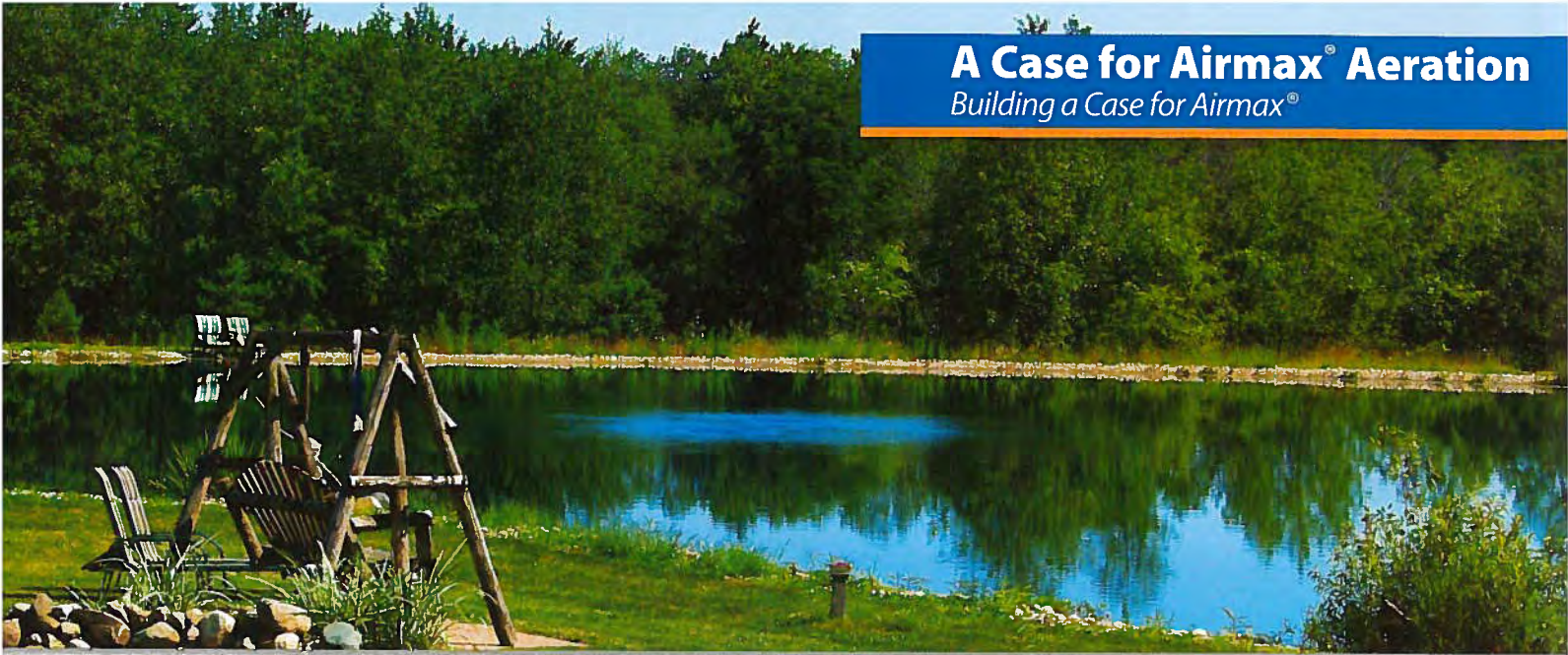

## Oxygen Saturation in 14 Days

Elongated 1/2 acre pond, 10' deep and the pond owners main concern was fish health and water clarity. With this in mind the oxygen and temperature levels were tested in 1' increments. This test showed that the pond was severely stratified. Just after 3', oxygen levels plummeted.

**PRESCRIPTION:** – Increase oxygen levels throughout the pond to promote healthy fish and water clarity. Due to the elongated pond, an AM60, two-plate, deep water aeration system.

**RESULTS:** Within 14 days of installation oxygen and water temperature were tested again. There was a dramatic change. Oxygen levels became nearly saturated and water temperatures became even from top to bottom ensuring complete circulation.

### Dissolved Oxygen by Depth

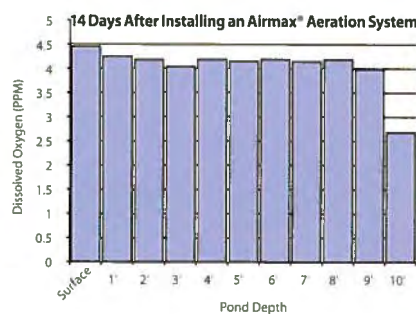
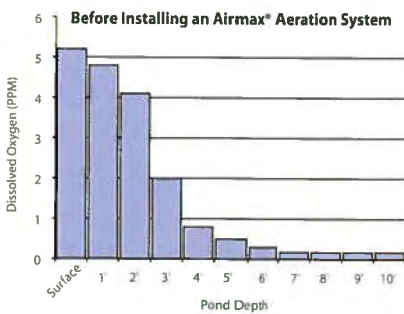

### Water Temperature by Depth

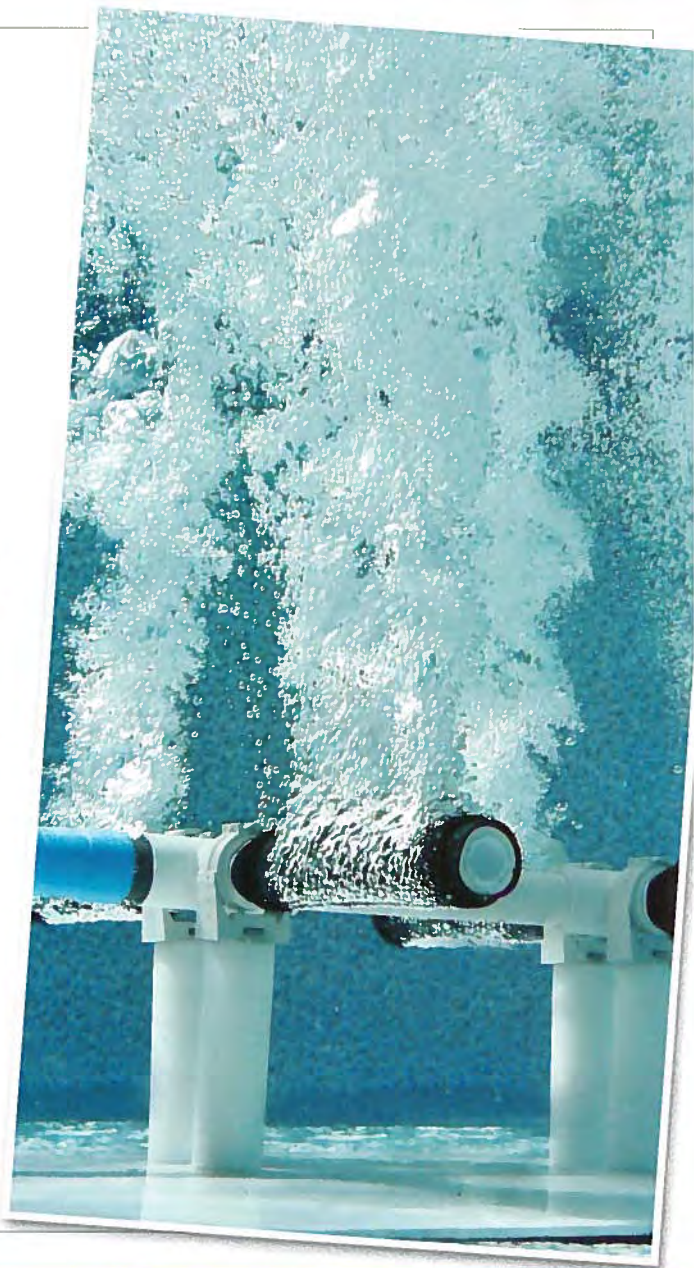
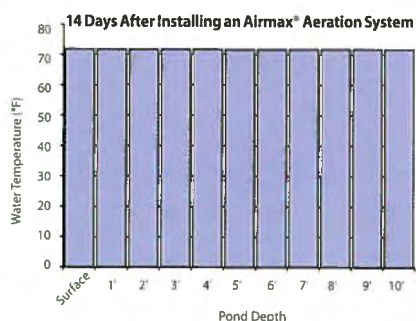
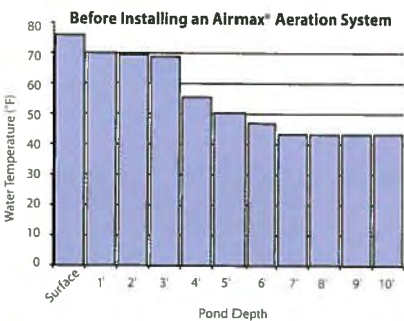



# Shallow Water Aeration Systems

For Ponds & Lakes up to 1 Acre, up to 8' Deep

## AM10-SW • Aerates Ponds up to 1/4 Acre



### AM10-SW Includes:

- Two ProAir™-2 Self-Weighted Diffuser Plates
- Standard SilentAir™ Composite Cabinet w/ Cooling Fan
- High Efficiency Diaphragm SilentAir™ Compressor w/ Double Manifold Assembly
- 100' or 200' EasySet™ Self-Weighted 3/8" Airline, Additional Airline Available

### Provides Aeration For:

Up to 1/4 Acre ..... up to 6' deep

### AM10-SW System Specs:

|                     |               |
|---------------------|---------------|
| Max/Running Amps    | 0.5           |
| Volts               | 115           |
| CFM                 | 2.5           |
| Max Operating Depth | 6'            |
| Op. Cost / Mo.*     | \$2.52 (24/7) |

### Diffuser Placement:



## AM20-SW • Aerates Ponds up to 1/2 Acre



### AM20-SW Includes:

- Four ProAir™-2 Self-Weighted Diffuser Plates
- Standard SilentAir™ Composite Cabinet w/ Cooling fan
- High Efficiency Diaphragm SilentAir™ Compressor w/ Quad Manifold Assembly
- 200' or 400' EasySet™ Self-Weighted 3/8" Airline, Additional Airline Available

### Provides Aeration For:

Up to 1/2 Acre ..... up to 8' deep

### AM20-SW System Specs:

|                     |               |
|---------------------|---------------|
| Max/Running Amps    | 0.9           |
| Volts               | 115           |
| CFM                 | 4.9           |
| Max Operating Depth | 8'            |
| Op. Cost / Mo.*     | \$5.04 (24/7) |

### Diffuser Placement:



## AM40-SW • Aerates Ponds up to 1 Acre



### AM40-SW Includes:

- Eight ProAir™-2 Self-Weighted Diffuser Plates
- Large SilentAir™ Composite Cabinet w/ High Volume Cooling Fan
- Two High Efficiency Diaphragm SilentAir™ Compressors w/ Quad Manifold Assemblies
- 400' EasySet™ Self-Weighted 3/8" Airline, Additional Airline Available

### Provides Aeration For:

Up to 1 Acre ..... up to 8' deep

### AM40-SW System Specs:

|                     |                |
|---------------------|----------------|
| Max/Running Amps    | 1.8            |
| Volts               | 115            |
| CFM                 | 9.8            |
| Max Operating Depth | 8'             |
| Op. Cost / Mo.*     | \$10.08 (24/7) |

### Diffuser Placement:



\* AM40-SW comes with a "Large" cabinet. See pg 6 for more details.



## SHALLOW WATER FEATURES

### SilentAir™ Standard Cabinet

For AM10-SW, AM20-SW & AM40-SW

\* AM40-SW comes with a "Large" cabinet. See pg 6 for more details.

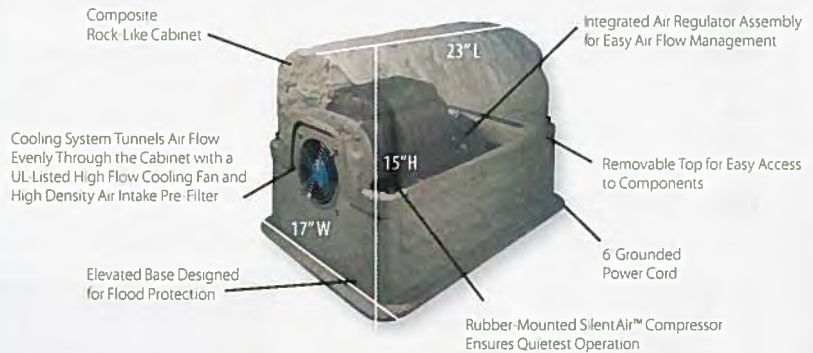

### ProAir™-2 Membrane Stick Diffuser Plate

For AM10-SW, AM20-SW & AM40-SW

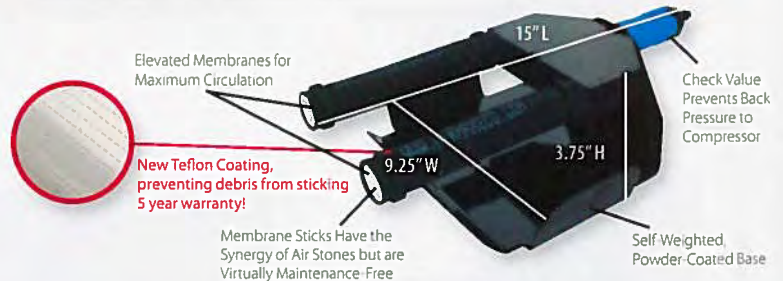

### EasySet™ Airline

#### Self-Weighted:

- No bricks, weights or ties needed.
- Kink-free, fish hook resistant & trouble free.

#### Direct Burial:

- Use from power source to pond's edge if power not at shore; up to 1,000 feet away.
- Remote valve box controls available for longer runs, call for details.





# Aeration Systems

For Ponds & Lakes up to 3 Acres, at least 6' Deep

## AM30 • Aerates Ponds up to 1 Acre



### AM30 Includes:

- One ProAir™-4 Self-Weighted Diffuser Plate
- Standard SilentAir™ Composite Cabinet w/ Cooling Fan
- 1/4 HP SilentAir™ Rocking Piston Compressor w/ Single Manifold Assembly
- 100' EasySet™ Self-Weighted 5/8" Airline, Additional Airline Available

### Provides Aeration For:

- Up to 1/4 Acre ..... 6'-9' deep
- Up to 1/2 Acre ..... 9'-12' deep
- Up to 1 Acre ..... 12'+ deep

### AM30 System Specs:

|                     |               |
|---------------------|---------------|
| Max Running Amps    | 3.1/1.2       |
| Volts               | 115           |
| CFM                 | 1.5           |
| Max Operating Depth | 50'           |
| Op. Cost / Mo.*     | \$6.96 (24/7) |

### Diffuser Placement:



## AERATION FEATURES

### SilentAir™ Standard Cabinet

For AM30, AM60 & AM70

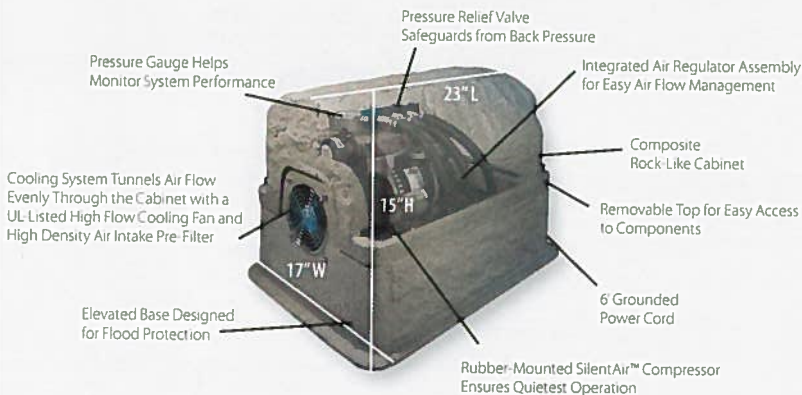

## AM60 • Aerates Ponds up to 2 Acres



### AM60 Includes:

- Two ProAir™-4 Self-Weighted Diffuser Plates
- Standard SilentAir™ Composite Cabinet w/ Cooling Fan
- 1/5 HP SilentAir™ Rocking Piston Compressor w/ Double Manifold Assembly
- 200' EasySet™ Self-Weighted 5/8" Airline, Additional Airline Available

### Provides Aeration For:

- Up to 1/2 Acre ..... 6'-9' deep
- Up to 1 Acre ..... 9'-12' deep
- Up to 2 Acres ..... 12'+ deep

### AM60 System Specs:

|                     |                |
|---------------------|----------------|
| Max Running Amps    | 5.3/3.5        |
| Volts               | 115            |
| CFM                 | 4.0            |
| Max Operating Depth | 30'            |
| Op. Cost / Mo.*     | \$20.29 (24/7) |

### Diffuser Placement:

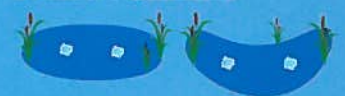

### ProAir™-4 Membrane Stick Diffuser Plate

For AM30, AM60 & AM70

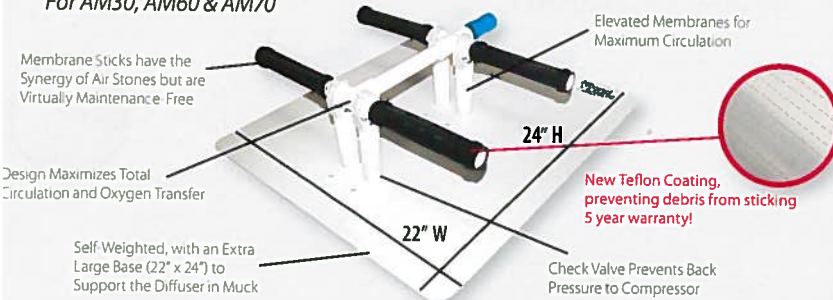

### EasySet™ Airline

#### Self-Weighted:

- No bricks, weights or ties needed.
- Kink-free, fish hook resistant & trouble free.

#### Direct Burial:

- Use from power source to pond's edge if power not at shore; up to 1,000 feet away.
- Remote valve box controls available for longer runs, call for details.



## AM70 • Aerates Ponds up to 3 Acres



### AM70 Includes:

- Three ProAir™-4 Self-Weighted Diffuser Plates
- Standard SilentAir™ Composite Cabinet w/ Cooling Fan
- 1/5 HP SilentAir™ Rocking Piston Compressor w/ Triple Manifold Assembly
- 500' or 600' EasySet™ Self-Weighted 3/8" Airline, Additional Airline Available

### Provides Aeration For:

- Up to 1 1/2 Acres ..... 6'-9' deep
- Up to 2 Acres ..... 9'-12' deep
- Up to 3 Acres ..... 12'+ deep

### AM70 System Specs:

|                     |                |
|---------------------|----------------|
| Max Running Amps    | 5.3/3.5        |
| Volts               | 115            |
| CFM                 | 4.0            |
| Max Operating Depth | 30'            |
| Op. Cost / Mo.*     | \$20.29 (24/7) |

### Diffuser Placement:





# Aeration Systems

For Ponds & Lakes up to 9 Acres, at least 6' Deep

## AM80 • Aerates Ponds up to 4 Acres



### AM80 Includes:

- Four ProAir™-4 Self-Weighted Diffuser Plates
- Large SilentAir™ Composite Cabinet w/ High Volume Cooling Fan
- Two 1/3 HP SilentAir™ Rocking Piston Compressors w/ Double Manifold Assembly
- Airline Sold Separately

### Provides Aeration For:

- Up to 2 Acres ..... 6'-9' deep
- Up to 3 Acres ..... 9'-12' deep
- Up to 4+ Acres ..... 12'+ deep

### AM70 System Specs:

|                     |                |
|---------------------|----------------|
| Max/Running Amps    | 10.6/7.0       |
| Volts               | 115            |
| CFM                 | 8.0            |
| Max Operating Depth | 30'            |
| Op. Cost / Mo.*     | \$40.58 (24/7) |

### Diffuser Placement:



## AM100 • Aerates Ponds up to 6 Acres



### AM100 Includes:

- Six ProAir™-4 Self-Weighted Diffuser Plates
- Large SilentAir™ Composite Cabinet w/ High Volume Cooling Fan
- Two 1/3 HP SilentAir™ Rocking Piston Compressors w/ Triple Manifold Assemblies
- Airline Sold Separately

### Provides Aeration For:

- Up to 3 Acres ..... 6'-9' deep
- Up to 4 Acres ..... 9'-12' deep
- Up to 6+ Acres ..... 12'+ deep

### AM100 System Specs:

|                     |                |
|---------------------|----------------|
| Max/Running Amps    | 10.6/7.0       |
| Volts               | 115            |
| CFM                 | 8.0            |
| Max Operating Depth | 30'            |
| Op. Cost / Mo.*     | \$40.58 (24/7) |

### Diffuser Placement:



## AM120 • Aerates Ponds up to 9 Acres



### AM120 Includes:

- Nine ProAir™-4 Self-Weighted Diffuser Plates
- Large SilentAir™ Composite Cabinet w/ High Volume Cooling Fan
- Three 1/3 HP SilentAir™ Rocking Piston Compressors w/ Triple Manifold Assemblies
- Airline Sold Separately

### Provides Aeration For:

- Up to 5 Acres ..... 6'-9' deep
- Up to 7 Acres ..... 9'-12' deep
- Up to 9+ Acres ..... 12'+ deep

### AM120 System Specs:

|                     |                |
|---------------------|----------------|
| Max/Running Amps    | 15.9/10.5      |
| Volts               | 115            |
| CFM                 | 12.0           |
| Max Operating Depth | 30'            |
| Op. Cost / Mo.*     | \$60.87 (24/7) |

### Diffuser Placement:



## AERATION FEATURES

### SilentAir™ Large Cabinet

For AM80, AM100 & AM120

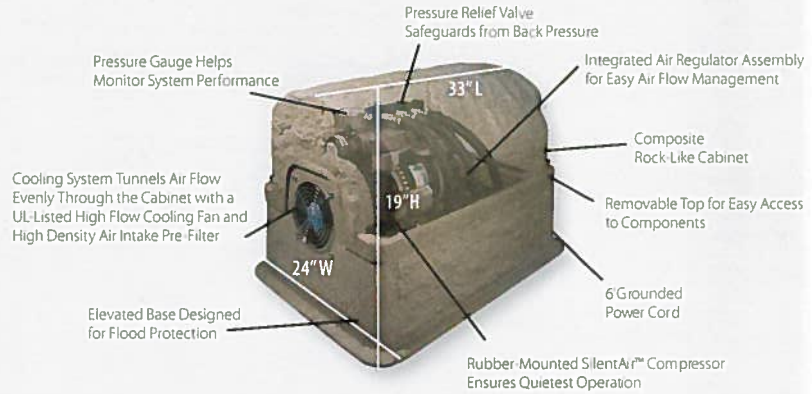

### ProAir™-4 Membrane Stick Diffuser Plate

For AM80, AM100 & AM120

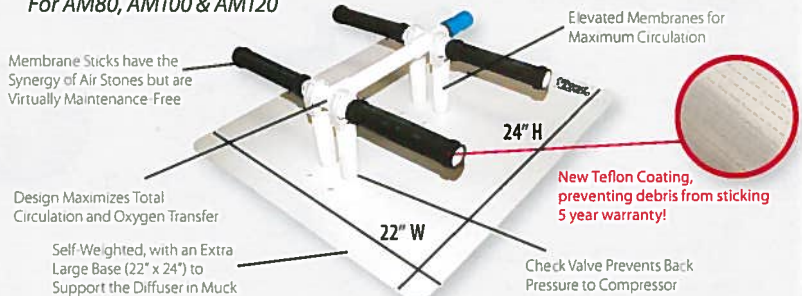

### EasySet™ Airline

#### Self-Weighted:

- No bricks, weights or ties needed.
- Kink-free, fish hook resistant & trouble free.

#### Direct Burial:

- Use from power source to pond's edge if power not at shore; up to 1,000 feet away.
- Remote valve box controls available for longer runs, call for details.





**Pc PondClear™** Natural Bacteria



Keep your pond crystal clear all season!

Murky Water

AFTER  
PondClear™

**Water Clarity, Naturally**

- Keeps ponds clean and clear all season.
- All natural.
- Pre-measured water soluble packets.
- Eliminates need for measuring.
- Available in three sizes: 3 lbs (12 packets), 6 lbs (24 packets) and a 24 lb (96 packets) Professional Size.
- 5-year shelf life.

**Dosage Rates:**

Use TWO packets every two weeks per 1/4 surface acre.  
6 lbs. treats 1/4 surface acre for 6 months.

**Ma MuckAway™** Natural Bacteria



Eliminates up to 5" of Muck per Year!

Pond Muck

AFTER  
MuckAway™

**Reduce Mucky Pond Bottoms**

- All natural way to eliminate mucky bottoms in ponds, beaches and shorelines.
- Precision release pellets sink to the bottom and consume up to 5" of muck per year.
- Consumes muck more effectively than using powder or liquids.
- Available in three sizes: 4 lbs, 8 lbs and a 24 lb Professional Size.
- 5-year shelf life.

**Dosage Rates:**

Use 1/2 lb. for every 1,000 sq. ft. of shoreline every 2-4 weeks.  
8 lbs. treats 1,500 sq. ft. (75 ft. of shoreline) for 6 months.

**Nb Tw Bk Pond Dye 4X** CONCENTRATED TREATS LIKE 1 GALLON!

**Beautifies Ponds**

- One concentrated quart treats 1 acre, 4'-6' deep.
- Choice of 3 colors.**
- Nature's Blue™ provides a true blue color. Contains full strength acid blue 9.
- Twilight Blue™ provides a blackish-blue shade to the pond.
- Black DyeMond™ provides a rich jet black shade and beautiful reflection to the pond.
- 5-year shelf life.



**Nb+ Tw+ Pond Dye Plus**

**Water Clarity and Shading, Naturally**

- Combined forces of Pond Dye and PondClear™ Bacteria for optimum results.
- One gallon treats up to 1 acre, 4'-6' deep.
- 2-year shelf life.



**Nb Bk Pond Dye Packets**

**Convenient Water Soluble Packets**

- The same great Pond Logic® Pond Dye, but in a convenient water soluble packet!
- One packet treats a 1/2 acre of water, 4'-6' deep. 2 packets are equal to one quart of Nature's Blue™ / Black DyeMond™ Pond Dye.
- Available in two colors, Nature's Blue™ or Black DyeMond™
- 5-year shelf life.

**Dosage Rates:**

ONE packet treats a 1/2 acre of water, 4'-6' deep.





# AirmaxAssist™

FREE Aerial Mapping Service

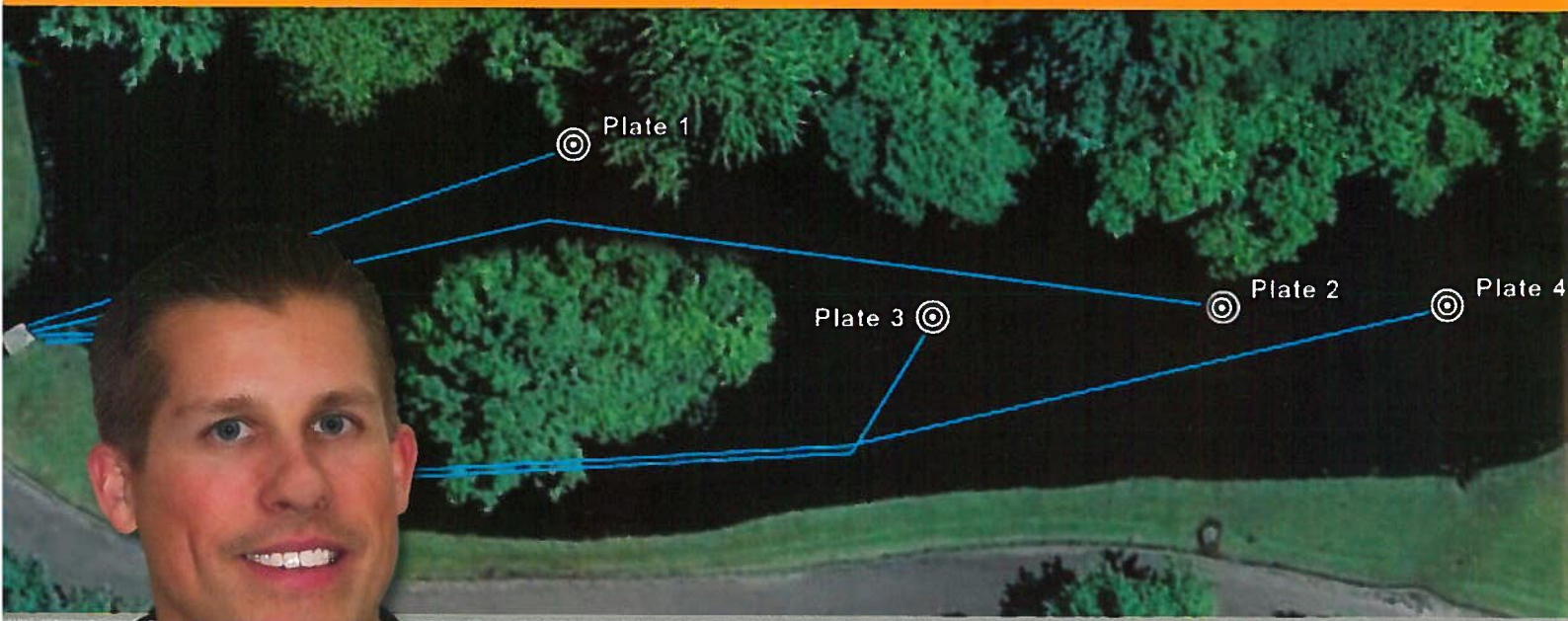

## Let Airmax® design the right system for you, saving you time and money, with AirmaxAssist™!

AirmaxAssist™ is designed to take the guesswork out of aeration design and pond management. Simply send us the address of where the pond is located along with approximate water depths.

Upon receipt we will map, measure and properly design an Airmax® Aeration System.

Upon completion of this FREE service you will be provided an aerial map with diffuser locations and complete system specifications.

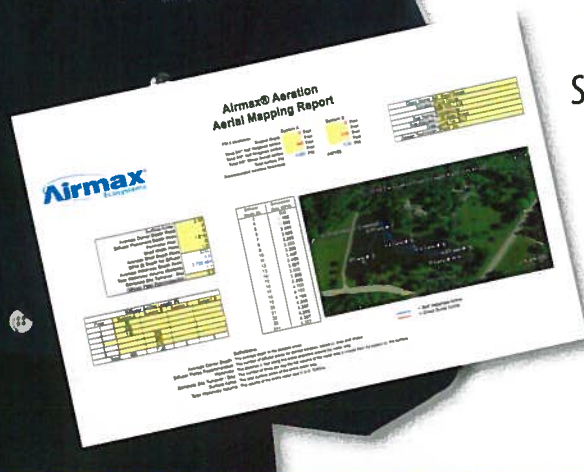

Contact your local dealer for more information!

**866-4-AIRMAX**  
866.424.7629

[www.airmaxeco.com](http://www.airmaxeco.com)

017\_12